

65TRTDi Threshold Drainage

Product Description

The 65TRTDi features a concealed channel section connecting sill and sub-sill for door tracks and thresholds. It is completed with a standard grate with a 3mm wire / 5mm gap. Legs at 350mm centers on the grates to make up the required depth

Allows door sills to be drained while having internal and external floor surfaces with no step down.

Manufactured from stainless steel to specific lengths.



Applications

- Balcony
- Courtyard / Patio
- Special needs
- Suspended slab
- Wet Area Drainage

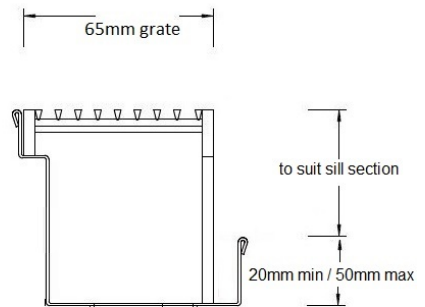

Specifications

	Width	Depth	Length	Outlet size
Unit	70mm	Subject to Sill Height	As required	As required

