

65TiG40 Assembly

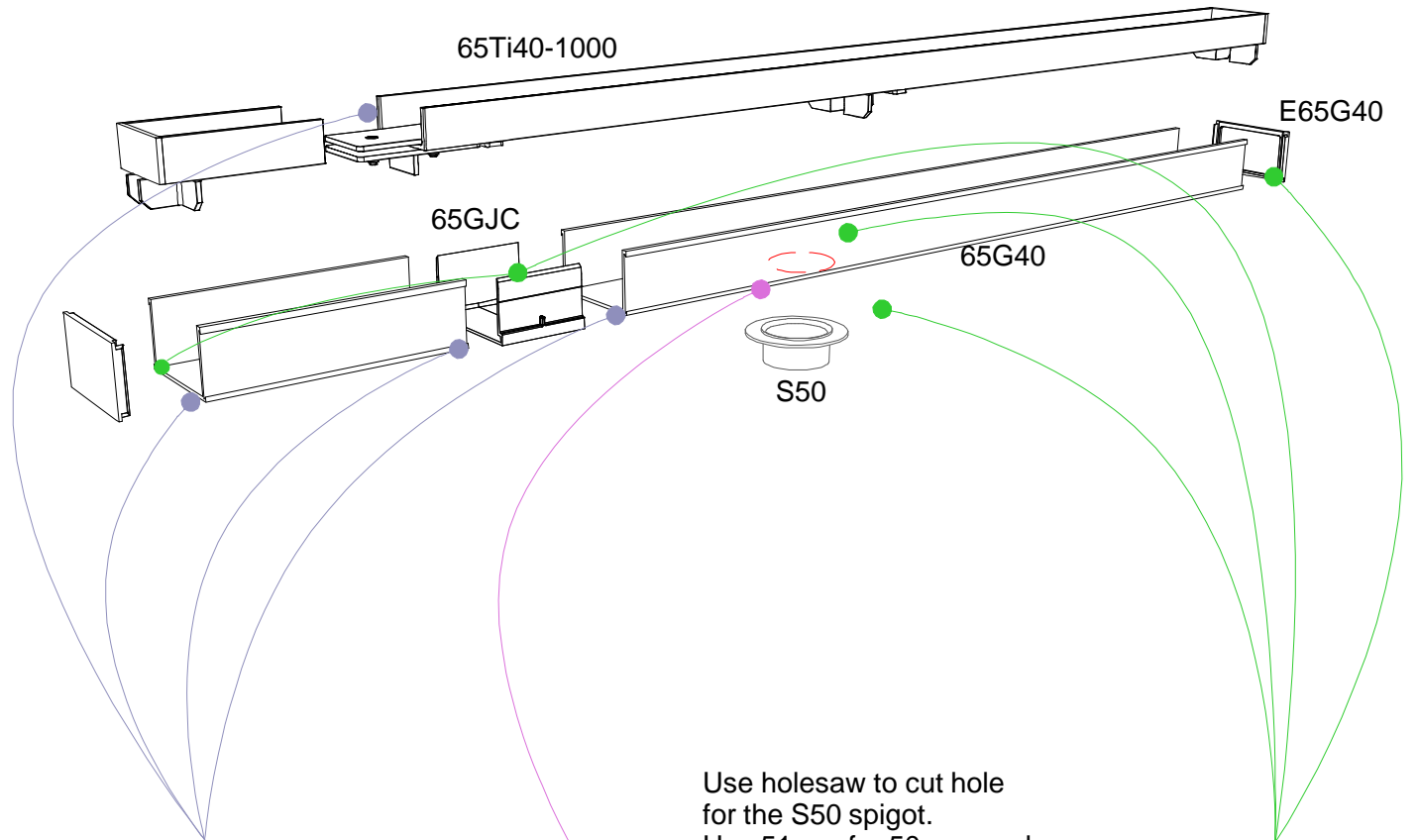

Use holesaw to cut hole for the S50 spigot. Use 51mm for 50mm, and 37 for 40mm DWV connections.

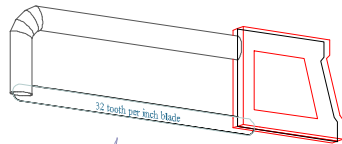
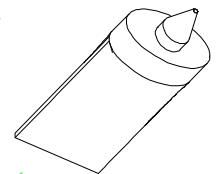
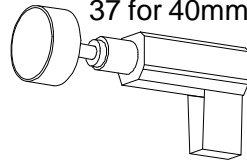

Use a hacksaw with 32TPI blade to cut both stainless Ti and PVC channel.
NOTE, cut the Ti AFTER the CHANNEL is ASSEMBLED to ensure the Ti fits correctly.

PVC solvent cement the parts together. Use type N clear with clear primer.

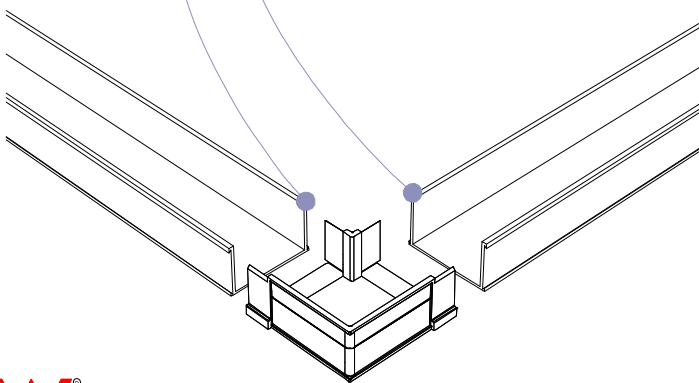

65GAM

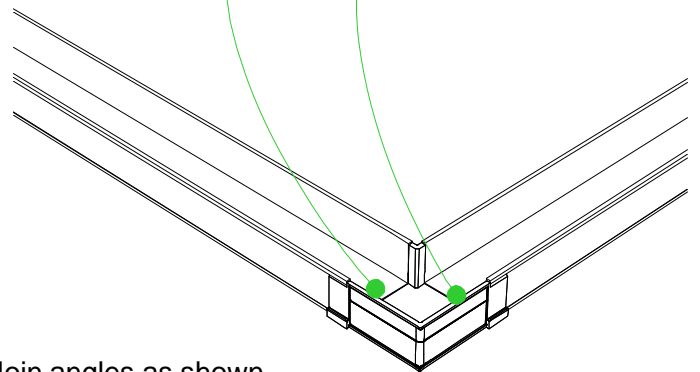

Join angles as shown if turning channel around a 90 degree corner.

