

65i25MTL TIMBER FLOOR/DECK

For 65ARi25MTL, 65ARiCO25, 65MNDi25MTL, 65MNDiCO25MTL, 65MNDiCO25, 65PHi25MTL, 65PHi25MTL, 65PSi25CO, 65PSi25MTL, 65PSiCO25, 65TRi25MTL, 65FTi25MTL and 65TRiCO25.

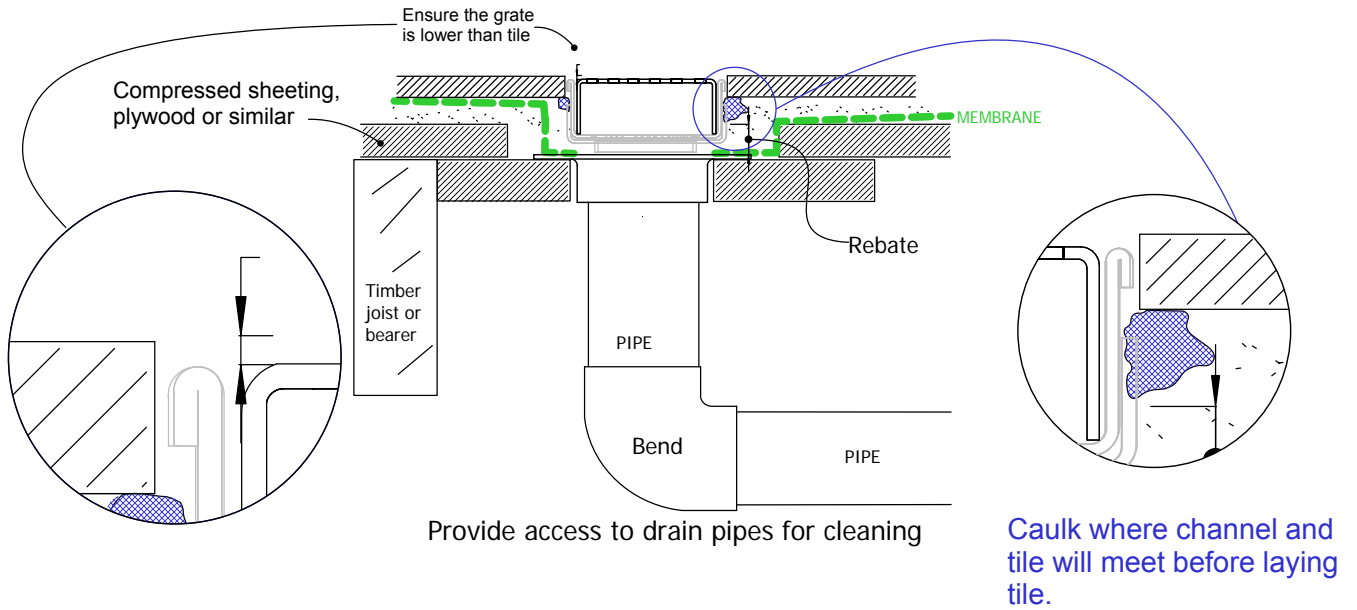

When 65i25MTL is running parallel to joist/bearer



When 65i25MTL is running perpendicular to joist/bearer

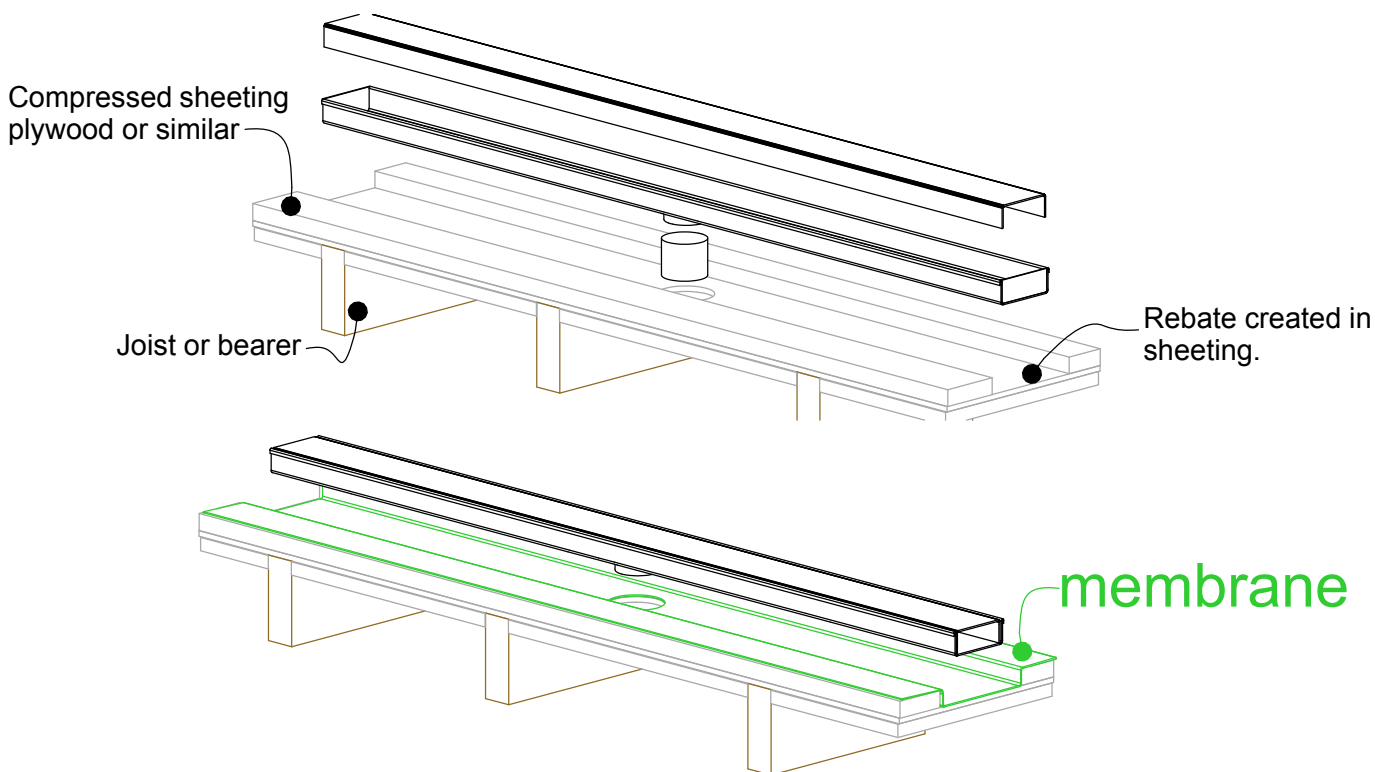

NOTE: For exterior application allow for expansion of 1mm 3 metres by using quality suitable flexible sealant on channel joins.